

GATEWAY INDOOR

USER GUIDE

INSTALLATION GUIDELINES

SIM Card Installation

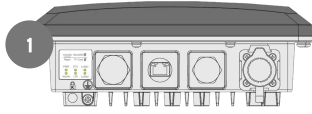

1 Start by unscrewing the cap of the NanoSIM interface on the gateway enclosure to expose the SIM card slot.

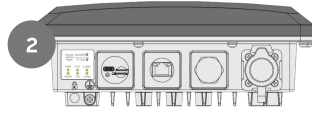

2 Push the SIM card into the card slot according to the placement method marked on the interface.

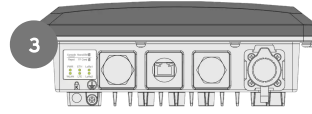

3 Once completed, screw back the metal cap. Make sure it is tightly screwed.

Mounting

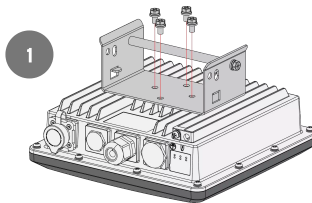

1 Fix the bracket included in the mounting kit on the bottom of the enclosure with four M6*12 screws.

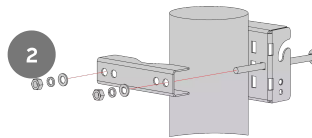

2 Position the pole clamps together around the pole, then tighten them with bolts, washers, and nuts.

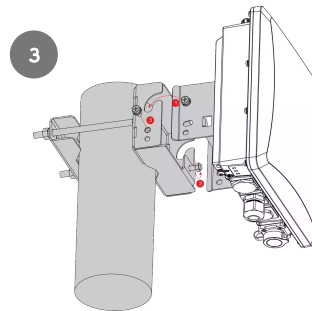

3 Mount the enclosure and secure it to the bracket.



Weather protection

To better protect the Ethernet cable gland and the antenna connector from the weather, you need to cover them with PVC tape.

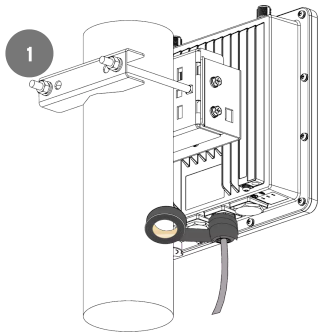

1
Clean the surface area of the connector that will be wrapped. Wrap a layer of PVC tape with a 50% overlap according to the rotation direction of the connector. Continue wrapping the PVC tape to about 10 mm below the end of the connector.

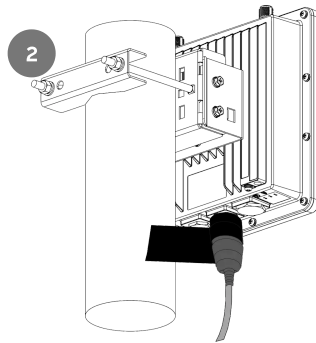

2
Cut off about 50 cm waterproof tape. Stretch it to double the length. Wrap three layers around the connector with a 50% overlap. Hold the tape in place with your hand for a few seconds.

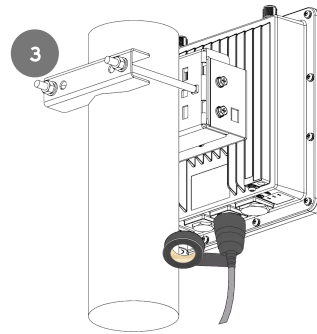

3
Wrap three additional layers with PVC tape with natural uncoiling force and a 50% overlap. Ensure to cover the head and the tail of the connector.

Connect the PoE Adapter

If you choose to power the gateway via PoE or access the gateway and internet via the ETH port, you need to refer to this section. Otherwise, skip it.

Connect one end of the Ethernet cable (Cat5e or better) to the ETH(PoE) port on the gateway and the other end to the PoE port of the PoE injector.

Connecting through ethernet

To access the Internet through the ETH (PoE) port, make sure you have completed the steps defined in the "Connect the PoE Adapter section".

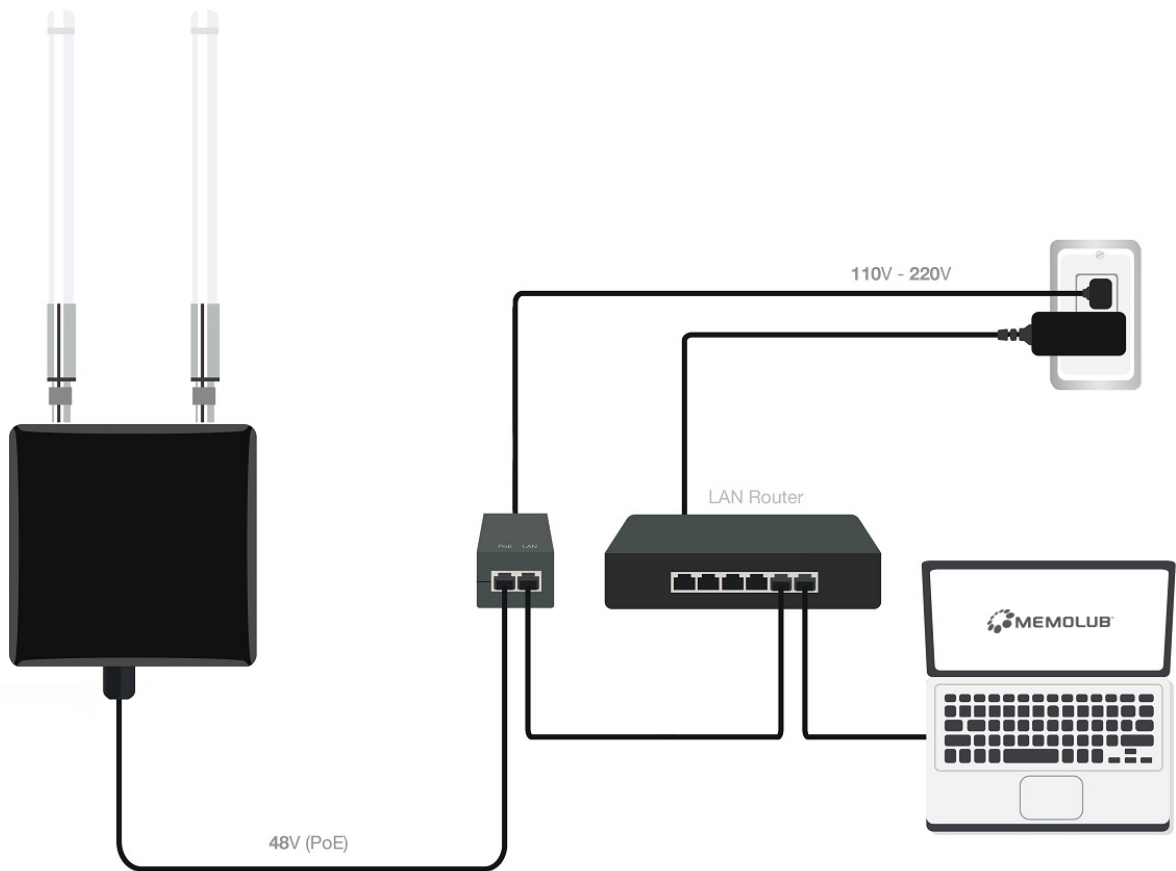

Lightning Protection

This section covers the installation of the lightning surge protection system when deploying the RAK7289V2/RAK2789CV2 gateway, both outdoors and indoors. Such a protection system must be taken into consideration to ensure a fully functional gateway without interruptions or damage from lightning.

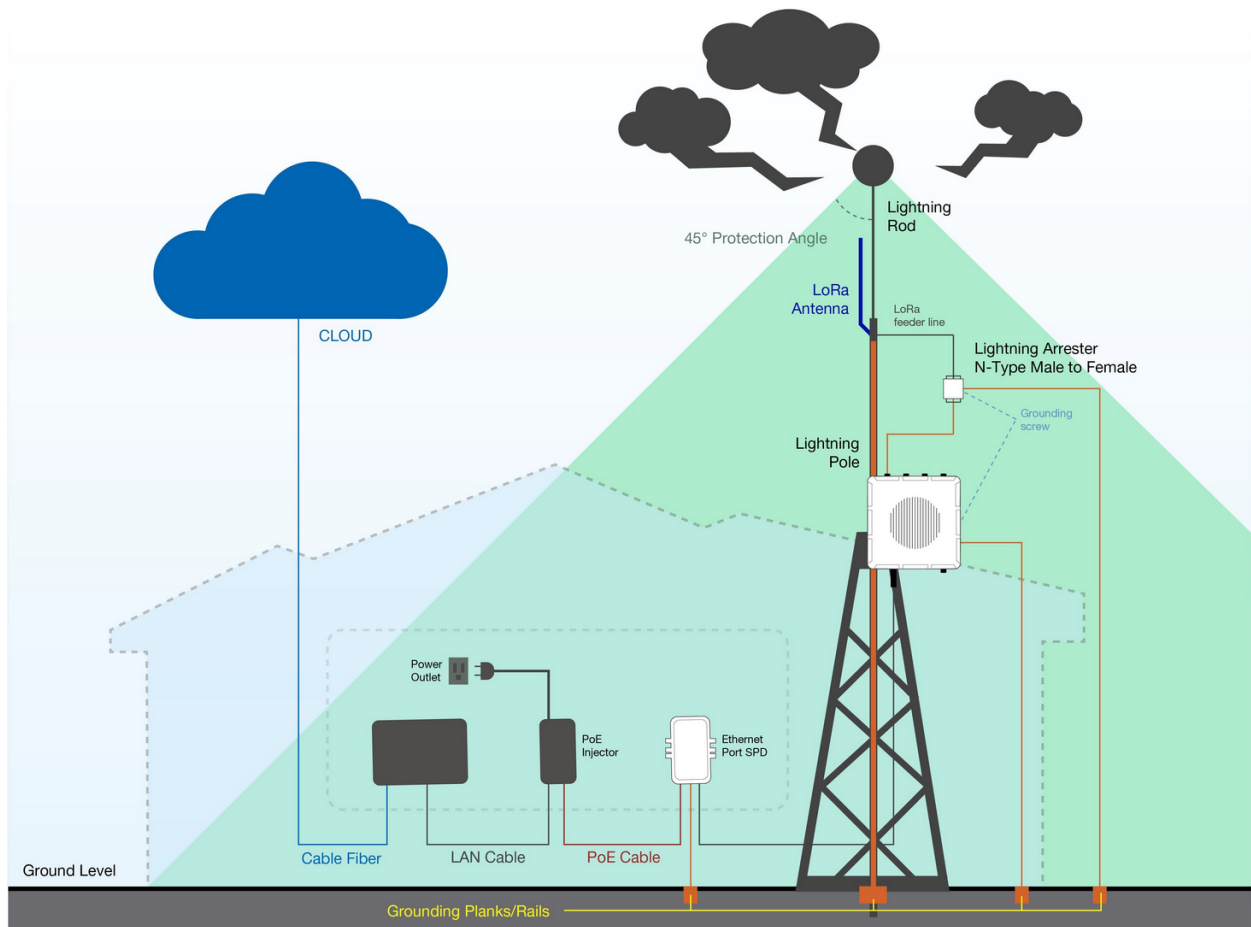

Outdoor Surge Protection System

Antenna Grounding: we recommend installing a lightning arrester on all the antenna N-type terminals. The arrestors must be N-type Female to Male to fit the antenna and enclosure connectors. Ensure you use a 10 AWG or better wire to connect the screw terminals of the arrestors to the grounding rail mounted on the building wall (grounding bar in the case of field deployment).

Gateway Grounding: Additionally, it is recommended to use another 10 AWG or better grounding wire to connect the screw terminal on the bottom-left side of the gateway casing to the grounding rail (bar).

No additional protection for the Ethernet cabling is required on the gateway side. It already has a built-in surge protection system (GDT + Anti-surge resistor).

Indoor Surge Protection

For protecting the indoor equipment and circuitry connected to the gateway, it is recommended to install an Ethernet port SPD lightning arrester. This device should be positioned along the cabling that connects the gateway to the PoE injector. Make sure you connect its grounding wire terminal to an appropriate building grounding point.

Should you fail to adhere to the recommendations in this document, RAKwireless carries no responsibility for any damage your equipment incurs due to a lightning strike.

Power On the Gateway

Do not power the device if any antenna port has been left open.

The gateway supports multiple power supply options. Connect the gateway to the appropriate power source based on your needs.

Power Cord + PoE Adapter: The gateway is powered via PoE, make sure you have completed the steps defined in the Connect the PoE Adapter section.

1. Connect one end of the power cord to the PoE adapter.
2. Connect the other end of power cord to a power outlet, your gateway can be powered on.

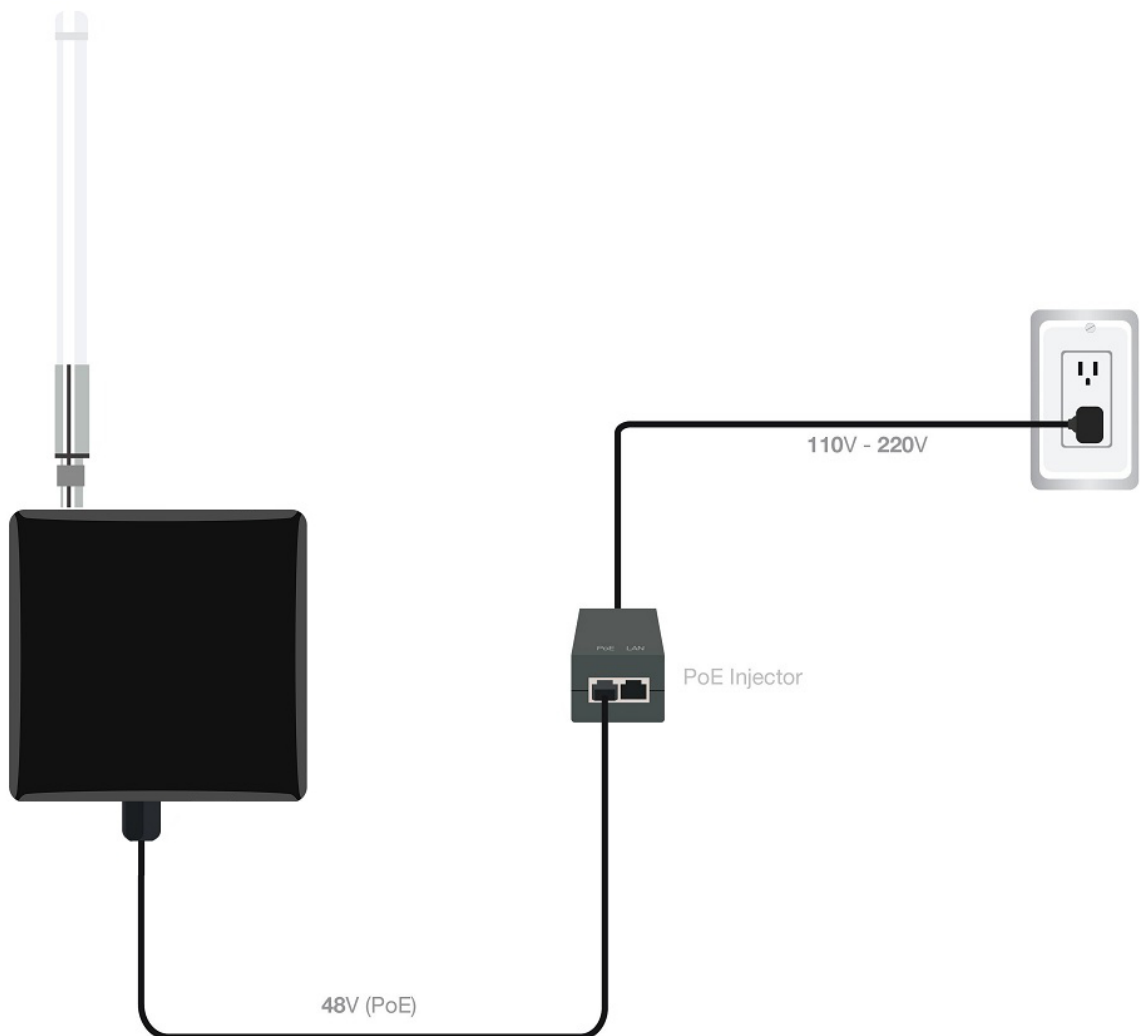

DC Cable: The gateway is powered by an external DC power supply. You need to use the DC cable to connect an external power supply. The external power supply voltage range: 12 V_{DC}.

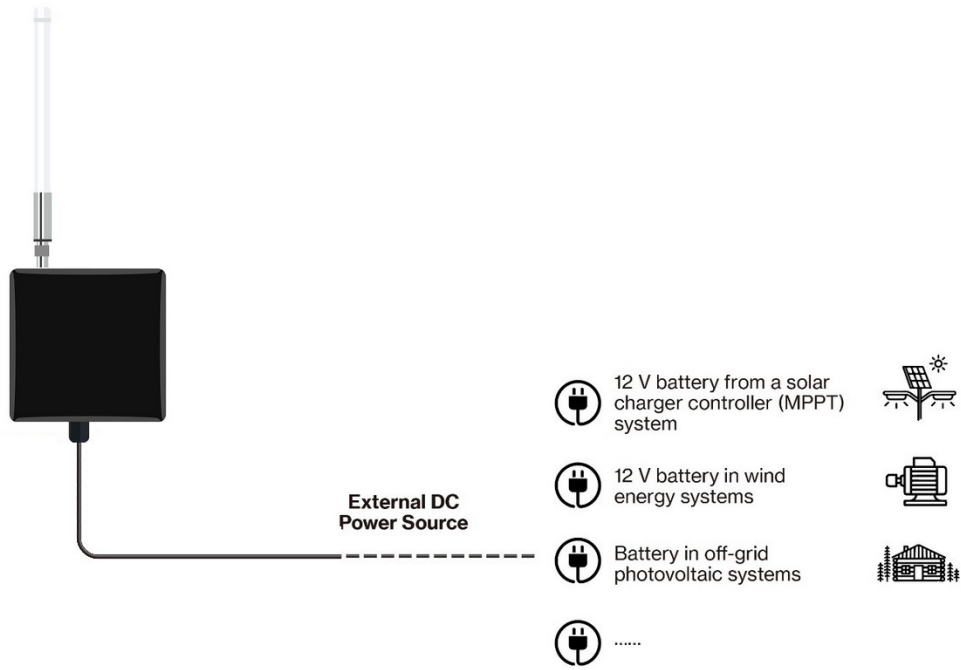

FAQ

How do I power the gateway safely?

The gateway should be powered using a 12V DC power supply or through PoE (Power over Ethernet, 802.3af). Do not use solar chargers directly. They can supply unstable voltages and may damage the device.

Can I use this gateway in off-grid or remote environments?

Yes. The gateway is compatible with the RAK Battery Plus, making it suitable for solar-powered or off-grid setups.

How do I manage the gateway remotely?

You can manage it using WisDM, RAK's cloud-based device management platform. It allows you to monitor, configure, and update your gateways remotely. Create a WisDM account, add your gateway by serial number, and start managing devices across your network. Ensure your gateway has internet access for cloud syncing.

Does the gateway support firmware updates over the air (FUOTA)?

Yes. WisGateOS 2 combined with WisDM enables **remote firmware updates**, configuration changes, and device monitoring.