

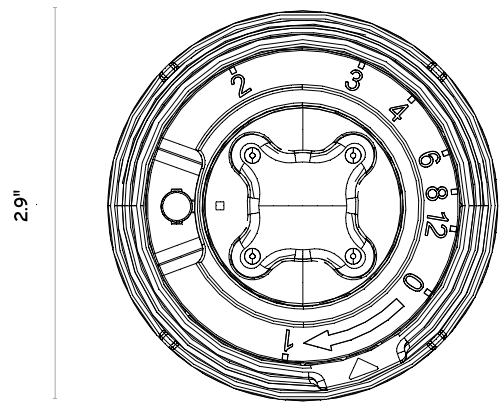

# GREASOMATIC® 96

## KNOWLEDGE BASE

### DIMENSIONS

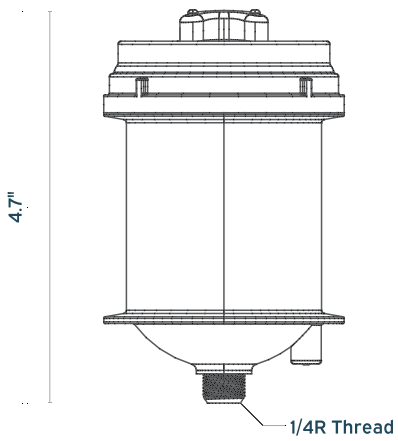

## SETTINGS

Dial Setting	Daily Output	Discharge Period
1	4 cc	1 month
2	2 cc	2 months
3	1.3cc	3 months
4	1 cc	4 months
6	0.7 cc	6 months
8	0.5 cc	8 months
12	0.3 cc	12 months

### AVERAGE AMBIENT TEMPERATURE CHART

The normal discharge durations of 1, 2, 3, 4, 6, 8 or 12 months apply at an ambient temperature of 68°F (+20°C). Output and discharge durations will vary if the GREASOMATIC operates at a higher or lower temperature. The table below illustrates the output and discharge durations at varied temperatures.

Dial Setting	+32°F	+50°F	+68°F	+86°F	+104°F
1	1 cc daily for 4 months	2 cc daily for 2 months	4 cc daily for 1 month	8 cc daily for 0.5 months	Not recommended
2	0.5 cc daily for 8 months	1 cc daily for 4 months	2 cc daily for 2 months	4 cc daily for 1 month	6 cc daily for 0.7 months
3	0.3 cc daily for 12 months	0.7 cc daily for 6 months	1.3 cc daily for 3 months	2.7 cc daily for 1.5 months	4 cc daily for 1 month
4	0.25 cc daily for 16 months	0.5 cc daily for 8 months	1 cc daily for 4 months	2 cc daily for 2 months	3 cc daily for 1.3 months
6	0.2 cc daily for 24 months	0.3 cc daily for 12 months	0.7 cc daily for 6 months	1.3 cc daily for 3 months	2 cc daily for 2 months
8	Not recommended	0.25 cc daily for 16 months	0.5 cc daily for 8 months	1 cc daily for 4 months	1.5 cc daily for 2.7 months
12	Not recommended	0.2 cc daily for 24 months	0.3 cc daily for 12 months	0.7 cc daily for 6 months	1 cc daily for 4 months

## INSTALLATION

### Grease Installation

- 1 On first installation, use a hand grease gun and the same type of lubricant to pre-charge all fittings, lines and the bearing. The thread of the GREASOMATIC® is 1/4 BSPT and can be adapted for other thread sizes using standard adapters.
- 2 Activate Greasomatic (see below)

### Oil Installation

- A Install the unit with the outlet in the up position and using a remote line to the bearing.
- B Install a check valve on the outlet of the GREASOMATIC® to prevent the oil from running out.

## ACTIVATION



Turn the control knob clockwise so the arrow is pointing to the desired monthly setting. If you turn the control knob to far and pass your desired setting, you can turn the knob counterclockwise back to zero and start again.



Press the red button until it is flush with the top surface. Once the red button is pressed the discharge rate can not be changed.



Rotate the black control knob clockwise 10 to 12 turns. This releases the galvanic element into the liquid electrolyte, thus activating the GREASOMATIC®.

**SPECIFICATIONS**

Housing Design	Plastic Body and Thread
----------------	-------------------------

Dimensions	2.9" x 4.7" (74mm x 120mm)
Capacity	120cc (4 oz)
Drive	Electrochemical
Electrolyte Liquid	Mildly Acidic Organic Acid
Temperature Range	32°F to 140°F (0°C to 60°C)
Max Pressure Build-Up	73 psi (5 bar)
Installation Thread	1/4 BSPT (Adapters Available)
Discharge Period	1, 2, 3, 4, 6, 8, or 12 months
Compatible Lubricants	Oil and Greases (up to NLGI2)

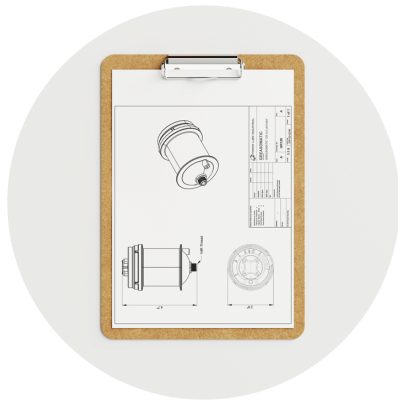

## TECHNICAL DRAWING

[DOWNLOAD](#)



## ATEX CERTIFICATION

[DOWNLOAD](#)



## CERBERUS CERTIFICATION



[DOWNLOAD](#)



## GREASOMATIC SDS

[DOWNLOAD](#)

## REGULATORY INFORMATION

SYMBOL	Description
	Heart -1; Flammability -1; Reactivity -0; Special - -
	ATEX Directive 94/9/EC
	This product can be recycled. Please arrange for the environmental appropriate disposal of the lubricator.